



**Fabricated Strainers**

**Fabricated “Y” Strainers**

Style FSA & FSSA; 150#, 300# and 600# Flanged or Butt Weld Connections .....2  
 Technical Data .....3

Style FSA & FSSA; 900#, 1500# and 2500# Flanged or Butt Weld Connections .....\*

**Fabricated Basket Strainers**

Style FB & FBQ; 150#, 300# and 600# Flanged or Butt Weld Connections .....4  
 Technical Data .....5

**Fabricated “Tee” Strainers**

Style T & TQ; 150#, 300# and 600# Flanged or Butt Weld Connections .....6  
 Technical Data .....7

**Temporary Strainers - Cone, Basket, Plate**

Style TC Temporary Cone Strainer, 150#, 300# and 600# .....8  
 Technical Data .....9

Style TB Temporary Basket Strainer, 150#, 300# and 600# .....8  
 Technical Data .....9

Style TP Temporary Plate Strainer, 150#, 300# and 600# .....8  
 Technical Data .....9

**Fabricated Quick Acting Line Blind**

Style FLB Fabricated Quick Acting Line Blind; 150# - 2500# .....10  
 Technical Data .....11

**Fabricated Flanged Offset Basket Strainers.....12**

**Optional Features .....13**

**Pressure Drop Charts**

Fabricated “Y” Strainers .....14  
 Fabricated Basket Strainers .....15  
 Fabricated “Tee” Strainers .....16  
 Fabricated Temporary Cone/Basket Strainers .....17-18

\*For Additional Pressure Classes and Materials of Construction (Low Carbon Steel, Alloy 20, Hastelloy C276, Monel, and Duplex Stainless Steel) visit [www.keckley.com](http://www.keckley.com)

## Style FSA

Fabricated Y-Strainer  
Carbon Steel

150 lb. Flanged & Butt Weld  
300 lb. Flanged & Butt Weld  
600 lb. Flanged & Butt Weld



## Style FSSA

Fabricated Y-Strainer  
Stainless Steel

150 lb. Flanged & Butt Weld  
300 lb. Flanged & Butt Weld  
600 lb. Flanged & Butt Weld

## Fabricated Y-Strainer

### APPLICATIONS

Steam, water, oil or gas where protection from foreign matter in a pipeline is required.

### CONSTRUCTION

The Keckley Style FSA (carbon steel) & FSSA (stainless steel) fabricated Y-type strainers are normally supplied with a bolted (slip hinge) cover and are available with either flanged or butt weld connections. Flanges are raised face and drilled in accordance with ASME B16.5 and come standard with back-faced boltholes.

Special dimensions are available. For additional pressure classes, flanges, and materials of construction (Low Carbon Steel, Alloy 20, Hastelloy C276, Monel, and Duplex Stainless Steel) visit [www.keckley.com](http://www.keckley.com).

### FEATURES

The Keckley Style FSA and FSSA strainer screens are piloted through the use of machined grooves in both the body and cover to ensure proper alignment. The cover gasket is designed for specific pressure and temperature ratings. Keckley Style FSA and FSSA strainers have studs and nuts and are furnished with a blow down plug as standard.

Blind covers are available upon request.

### SCREENS

Standard screens are perforated 304 stainless steel and are spot welded for maximum strength. Different size perforations and meshes are available in stainless steel, monel, and brass to meet specific media requirements. If media is not indicated, 1/8" perforated 304 stainless steel screens will be supplied.

### SELF CLEANING

Self cleaning of the Style FSA and FSSA strainers are accomplished by opening the valve or drain plug connected to the blow off port. **Warning:** See Maintenance Instructions on page S6 of the Strainer Information Section for additional precautions and detailed information on servicing the strainer.

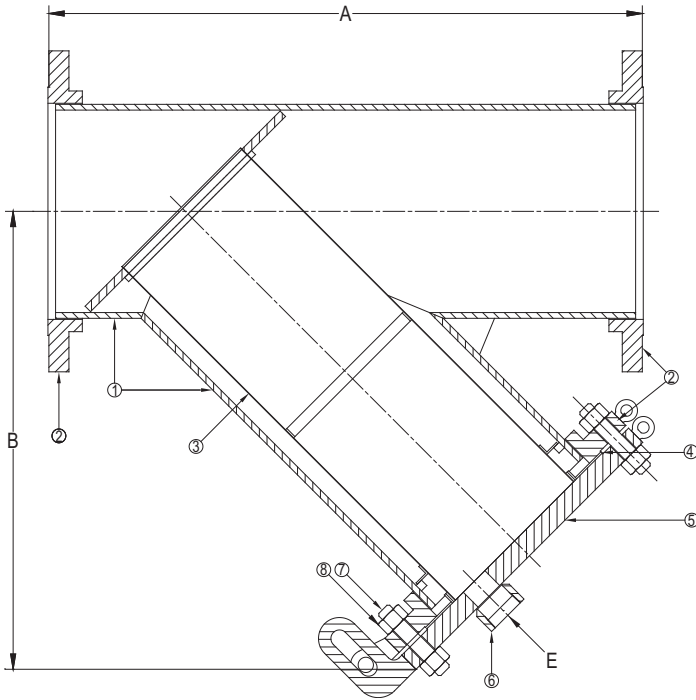

## Style FSA

### Fabricated Y- Strainer

### Carbon Steel

PARTS LIST		
ITEM	DESCRIPTION	MATERIAL
1	Pipe	Carbon Steel Pipe (ASTM A 53)
2	RFSO Flange	Carbon Steel (ASTM A 105) B16.5
3	Screen	Stainless Steel (304) - 1/8" Perforations
4	Gasket	Fiber
5	Blind Flange (Cover)	Carbon Steel (ASTM A 105)
6	3000# NPT Half Coupling	Carbon Steel (ASTM A 105)
7	Stud	Carbon Steel (ASTM A 193, Grade B7)
8	Nut	Carbon Steel (ASTM A 194, Grade 2H)

Options: Other meshes, perforations, and screen materials are available.

## Style FSSA

### Fabricated Y- Strainer

### Stainless Steel

PARTS LIST		
ITEM	DESCRIPTION	MATERIAL
1	Pipe	Stainless Steel (ASTM A 312, Grade TP-316)
2	RFSO Flange	Stainless Steel (ASTM A 182, Grade F-316)B16.5
3	Screen	Stainless Steel (304) - 1/8" Perforations
4	Gasket	Fiber
5	Blind Flange (Cover)	Stainless Steel (ASTM A 182, Grade F-316)
6	3000# NPT Half Coupling	Stainless Steel (ASTM A 182, Grade F-316)
7	Stud	Carbon Steel (ASTM A 193, Grade B7)
8	Nut	Carbon Steel (ASTM A 194, Grade 2H)

Options: Other meshes, perforations, and screen materials are available.

**Notes:**

Consult factory for additional pressure classes, flange types, pipe grades, and materials of construction.

SIZE		DIMENSIONS										WEIGHTS			
		A				B				E		150#		300#	
		150#	300#	150#	300#	150# & 300#	150#	300#	in	mm	lbs	kgs	lbs	kgs	
in	mm	in	mm	in	mm	in	mm	in	mm	in	mm	lbs	kgs	lbs	kgs
4	100	16	406	18	457	12	305	13	330	1	25	100	45	140	64
5	125	19	483	21	533	14	356	15	381	1	25	130	59	200	91
6	150	22	559	24	610	16	406	19	483	1	25	175	79	265	120
8	200	26	660	28	711	19	483	22	559	1-1/2	40	280	127	410	186
10	250	30	762	31	787	24	610	24	610	1-1/2	40	390	177	600	272
12	300	35	889	36	914	26	660	27	686	1-1/2	40	560	254	840	381
14	350	39	991	41	1041	30	762	32	813	2	50	800	363	1100	499
16	400	45	1143	47	1194	34	864	36	914	2	50	1000	454	1500	680
18	450	46	1168	50	1270	34	864	36	914	2	50	1150	522	1775	805
20	500	52	1321	55	1397	38	965	40	1016	2	50	1400	635	2100	953
24	600	60	1524	62	1575	44	1118	46	1168	2	50	2000	907	3100	1406
30*	750	72	1829	74	1880	50	1270	53	1346	2	50	3000	1361	5150	2336

\*30" Flanges are RFWN Series B.

Certified dimensional drawings are available upon request.

\*This table reflects only the nearest metric equivalents.

**FLOW COEFFICIENTS**

Size	C <sub>v</sub>	Size	C <sub>v</sub>	Size	C <sub>v</sub>
8"	759	14"	2182	20"	4902
10"	1233	16"	2878	24"	6641
12"	1740	18"	3479	30"	9487

**COVER WEIGHTS**

Size	4"	5"	6"	8"	10"	12"	14"	16"	18"	20"	24"	30"
150	lbs	13	15	19	30	43	64	90	106	130	165	150
	kgs	6	7	9	14	20	29	41	48	59	75	68
300	lbs	24	31	39	58	81	115	165	220	280	325	550
	kgs	11	14	18	26	37	52	75	100	127	147	249

## Style FB

Fabricated Basket Strainer

Bolted Cover

Carbon Steel & Stainless Steel

150 lb. Flanged & Butt Weld

300 lb. Flanged & Butt Weld

600 lb. Flanged & Butt Weld



## Style FB-Q

Fabricated Basket Strainer

Quick Open Cover

Carbon Steel & Stainless Steel

150 lb. Flanged & Butt Weld

300 lb. Flanged & Butt Weld

600 lb. Flanged & Butt Weld

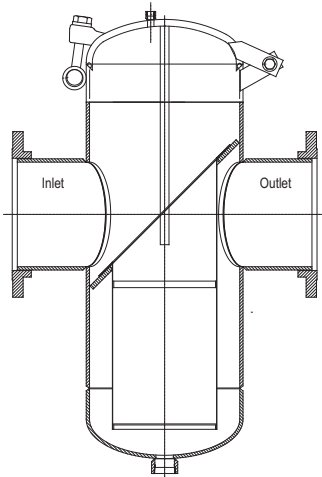

## Fabricated Basket Strainer

### APPLICATIONS

Steam, water, oil or gas where protection from foreign matter in a pipeline is required.

### CONSTRUCTION

The Keckley Style FB family of fabricated basket strainers are available in carbon steel or stainless steel. Either flanged or butt weld connections are furnished. These basket strainers are available with a Quick Open Cover (FB-Q), Bolted Slip Hinge Cover (FB-H), or Integral Swing Arm Davit Assembly (Style FB-D). Flanges are raised face and drilled in accordance with ASME B16.5 and come standard with back-faced boltholes.

Special dimensions are available. For additional pressure classes, flanges, and materials of construction (Low Carbon Steel, Alloy 20, Hastelloy C276, Monel, and Duplex Stainless Steel) visit [www.keckley.com](http://www.keckley.com).

### BASKETS

Baskets are perforated 304 stainless steel and are spot welded for maximum strength. Different size perforations and meshes are available in stainless steel, monel, and brass to meet specific media requirements. If media is not indicated, 1/8" perforated 304 stainless steel baskets will be supplied.

### CLEANING

Cleaning of the Style FB strainer is accomplished by removing the cover and pulling out the basket. **Warning:** See Maintenance Instructions on page S6 of the Strainer Information Section for additional precautions and detailed information on servicing the strainer.

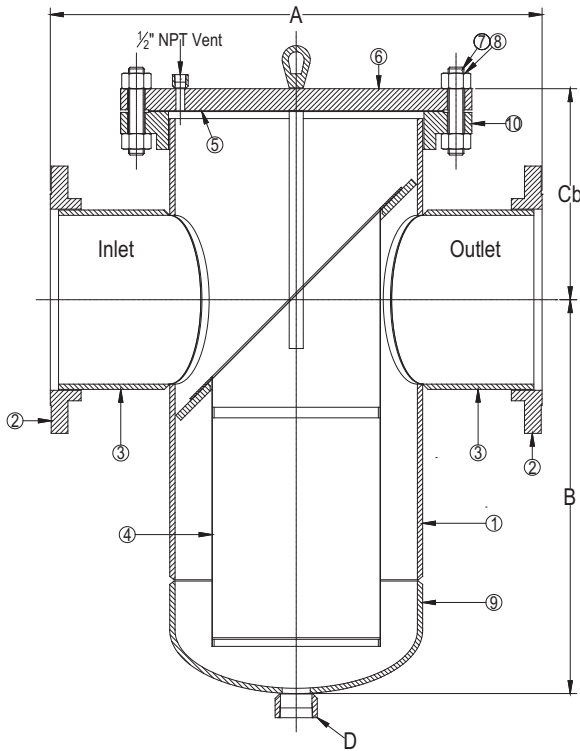

# Style FB

## Fabricated Basket Strainer

PARTS LIST				
ITEM	DESCRIPTION	MATERIAL		
1	Pipe	Carbon Steel	304 SS	316 SS
2*	RFSO Flange	Carbon Steel	304 SS	316 SS
3	Nozzle	Carbon Steel	304 SS	316 SS
4	Basket	Stainless Steel (304) - 1/8" Perforations		
5	Gasket	Fiber		
6	Blind Flange (Cover)	Carbon Steel	304 SS	316 SS
7	Studs	Carbon Steel (ASTM A 193, Grade B7)		
8	Nuts	Carbon Steel (ASTM A 194, Grade 2H)		
9	Weld Cap	Carbon Steel	304 SS	316 SS
10*	RFSO Flange	Carbon Steel	304 SS	316 SS

\*30" & Larger Flanges are RFWN Series B.

Options: Other meshes, perforations, and screen materials are available.

### Cover Options

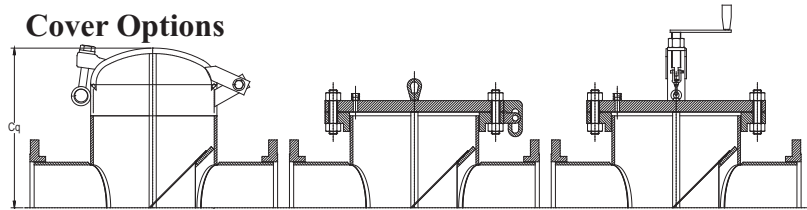

**Style FB-Q**  
Quick Open Cover

**Style FB-H**  
Bolted Slide Hinge Cover

**Style FB-D**  
Integral Davit Swing Arm

**Notes:**

Consult factory for additional pressure classes, flange types, pipe grades, and materials of construction. Furnished standard with 1/2" NPT Vent.

SIZE		DIMENSIONS															
		A				B		Cb				Cq		D		Body Housing (Pipe Size)	
		150#		300#				150#		300#							
in	mm	in	mm	in	mm	in	mm	in	mm	in	mm	in	mm	in	mm	in	mm
4	100	16	406	17	432	14	356	10-1/2	267	12-1/2	318	11	279	1	25	8	200
5	125	16	406	17	432	15	381	11	279	13	330	13	330	1	25	8	200
6	150	20	508	21	533	17	432	11	279	13	330	13	330	1	25	10	250
8	200	22	559	23	584	21	533	12	305	14	356	15	381	1-1/2	40	12	300
10	250	32	813	33	838	25	635	13	330	15	381	17	432	1-1/2	40	16	400
12	300	35	889	36	914	28	711	15	381	17	432	19	483	1-1/2	40	18	450
14	350	37	940	38	965	33	838	16-1/2	419	18-1/2	470	20	508	2	50	20	500
16	400	42	1067	43	1092	36	914	17-1/2	445	19-1/2	495	23	584	2	50	24	600
18	450	42	1067	43	1092	39	991	18-1/2	470	20	508	24	610	2	50	24	600
20	500	43	1092	44-1/2	1130	44	1118	20	508	25	635	24	610	2	50	30	750
24	600	48	1219	49	1245	44	1118	21	533	27	686	27	686	2	50	30	750
30	750	60	1524	63	1600	54	1372	31	787	35	889	33	838	2	50	36	900

SIZE		WEIGHT												FB-Q Force required to lift cover	
		FB						FB-Q							
		Total Weight			Cover Weight			Total Weight			Cover Weight				
		150#		300#		150#		300#		150#		300#			
in	mm	lbs	kgs	lbs	kgs	lbs	kgs	lbs	kgs	lbs	kgs	lbs	kgs	lbs	kgs
4	100	211	96	289	131	47	21	81	37	157	71	180	82	9	4
5	125	250	113	310	141	47	21	81	37	170	77	210	95	9	4
6	150	293	133	421	191	70	32	124	56	222	101	260	118	12	5
8	200	403	183	591	268	123	56	185	84	297	135	353	160	15	7
10	250	630	286	962	436	180	82	315	143	432	196	515	234	26	12
12	300	765	347	1283	582	220	100	415	188	539	244	758	344	32	15
14	350	951	431	1590	721	285	129	515	234	655	297	958	435	40	18
16	400	1323	600	2321	1053	430	195	800	363	870	395	1335	606	58	26
18	450	1357	616	2487	1128	430	195	800	363	904	410	1501	681	58	26
20	500	1943	881	3695	1676	543	246	1249	567	1193	541	1813	822	76	34
24	600	2120	962	4075	1848	543	246	1249	567	1370	621	2193	995	76	34
30	750	3063	1389	6100	2767	890	404	1921	871	2520	1143	5151	2336	149	68

\*This table reflects only the nearest metric equivalents.

## Style T

Fabricated Tee Strainer

Bolted Cover

Carbon Steel & Stainless Steel

150 lb. Flanged & Butt Weld

300 lb. Flanged & Butt Weld

600 lb. Flanged & Butt Weld



## Style TQ

Fabricated Tee Strainer

Quick Open Cover

Carbon Steel & Stainless Steel

150 lb. Flanged & Butt Weld

300 lb. Flanged & Butt Weld

600 lb. Flanged & Butt Weld



## Fabricated Tee Strainer

### APPLICATIONS

Steam, water, oil or gas where protection from foreign matter in a pipeline is required.

### CONSTRUCTION

The Keckley Style T “Tee” strainers are supplied with weld neck flange or butt weld connections. Ring Type Joint connections are also available; for ring type joint specify ring number and style.

The Style T & TQ strainers are suitable for either horizontal or vertical (downward flow) piping.

Special dimensions are available. For additional pressure classes, flanges, and materials of construction (Low Carbon Steel, Alloy 20, Hastelloy C276, Monel, and Duplex Stainless Steel) visit [www.keckley.com](http://www.keckley.com).

### BASKETS

Standard baskets are 1/8” perforated 304 stainless steel (approximately 6 mesh) and are spot welded for maximum strength. Different size perforations and meshes are available in stainless steel, monel, and brass to meet specific media requirements.

### SELF CLEANING

Self cleaning of the Style T & TQ strainers is accomplished (depending upon orientation) by either opening the valve or drain plug connected to the blow off port or removing the cover and pulling out the basket. **Warning:** See Maintenance Instructions on page S6 of the Strainer Information Section for additional precautions and detailed information on servicing the strainer.



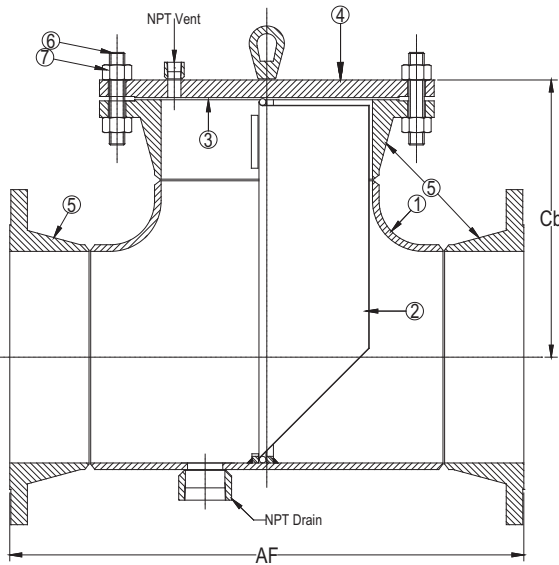

## Style T Fabricated Tee Strainer

PARTS LIST				
ITEM	DESCRIPTION	MATERIAL		
1	Body	Carbon Steel	304 SS	316 SS
2	Basket	Stainless Steel (304) - 1/8" Perforations		
3	Gasket	Fiber		
4	Blind Flange (Cover)	Carbon Steel	304 SS	316 SS
5*	RFWN Flange	Carbon Steel	304 SS	316 SS
6	Studs	Carbon Steel (ASTM A 193, Grade B7)		
7	Nuts	Carbon Steel (ASTM A 194, Grade 2H)		

\*30" & Larger Flanges are RFWN Series B.

Options: Other meshes, perforations, and screen materials are available.

### Cover Options

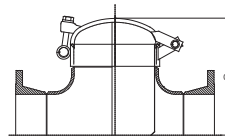

**Style TQ**  
Quick Open Cover

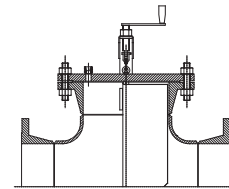

**Style TD**  
Integral Davit Swing Arm

### Notes:

Consult factory for additional pressure classes, flange types, pipe grades, and materials of construction. Furnished standard with 1/2" NPT Vent. (Sizes 2"-3" 1/8" NPT Vent.)

SIZE		DIMENSIONS																Drain Size	
		AF				AW		Cb				Cq							
		150#		300#				150#		300#		150#		300#					
in	mm	in	mm	in	mm	in	mm	in	mm	in	mm	in	mm	in	mm	in	mm		
2	50	10	254	10-1/2	267	5	127	5-3/4	146	6-1/8	156	--	--	--	--	1/2	15		
2-1/2	65	11-1/2	292	12	305	6	152	6-5/8	168	7	178	--	--	--	--	1/2	15		
3	80	12-1/4	311	13	330	6-3/4	171	7-1/8	181	7-5/8	194	--	--	--	--	3/4	20		
4	100	14-1/4	362	15	381	8-1/4	210	8-1/8	206	8-3/4	222	--	--	--	--	3/4	20		
5	125	16-3/4	425	17-1/2	445	9-3/4	248	9-3/8	238	10-1/8	257	--	--	--	--	1	25		
6	150	18-1/4	464	19	483	11-1/4	286	10-1/8	257	11	279	9-1/4	235	9-5/8	244	2	50		
8	200	22	559	22-3/4	578	14	356	12-1/8	308	13	330	10-5/8	270	11-1/8	283	2	50		
10	250	25	635	26-1/4	667	17	432	13-3/4	349	15	381	13-1/8	333	13-1/2	343	2	50		
12	300	29	737	30-1/4	768	20	508	15-3/4	400	17-1/8	435	15-5/8	397	15-5/8	397	2	50		
14	350	32	813	33-1/4	845	22	559	17-3/8	441	18-3/4	476	16-1/8	410	17-1/8	435	2	50		
16	400	34	864	35-1/2	902	24	610	18-1/2	470	20	508	18-5/8	473	18-5/8	473	2	50		
18	450	38	965	39-1/2	1003	27	686	20-5/8	524	22-1/8	562	20-7/8	530	21-1/8	537	2	50		
20	500	41-3/8	1051	42-3/4	1086	30	762	22-3/8	568	23-7/8	606	23-5/8	600	23-5/8	600	2	50		
24	600	46	1168	47-1/4	1200	34	864	24-7/8	632	26-3/8	670	27-1/8	689	27-1/8	689	2	50		
30	750	30	762	34-1/2	876	22	559	27-7/8	708	31-7/8	694	--	--	--	--	2	50		

SIZE		WEIGHT												TQ Force required to lift cover	
		T						TQ							
		Total Weight				Cover Weight				Total Weight					
in	mm	150#		300#		150#		300#		150#		300#		lbs	kgs
		lbs	kgs	lbs	kgs	lbs	kgs	lbs	kgs	lbs	kgs	lbs	kgs		
2	50	29	13	39	18	5	2	8	4	--	--	--	--	--	--
2-1/2	65	53	24	54	24	7	3	12	5	--	--	--	--	--	--
3	80	59	27	78	33	9	4	16	7	--	--	--	--	--	--
4	100	92	42	117	53	17	8	28	13	--	--	--	--	--	--
5	125	100	45	158	72	20	9	37	17	--	--	--	--	--	--
6	150	136	62	206	93	27	12	50	23	94	43	129	59	4	2
8	200	230	104	322	446	47	21	81	37	154	70	221	100	9	4
10	250	394	179	481	218	70	32	124	56	235	107	311	141	12	5
12	300	520	236	702	318	123	56	185	84	355	161	463	210	15	7
14	350	725	329	1033	469	140	64	250	113	465	211	626	284	20	9
16	400	946	429	1275	578	180	82	315	143	562	255	785	356	26	12
18	450	1129	512	1735	787	220	100	415	188	750	340	1150	522	32	15
20	500	1452	659	2165	982	285	129	515	234	1100	499	1600	726	40	18
24	600	2300	1043	3170	1438	430	195	800	363	1600	726	2150	975	58	26
30	750	1919	870	4059	1841	513	233	1249	567	--	--	--	--	--	--

\*This table reflects only the nearest metric equivalents.

## Style TC

Temporary Cone Strainer  
Carbon Steel & Stainless Steel  
150 lb., 300 lb., & 600 lb.



## Style TB

Temporary Basket Strainer  
Carbon Steel & Stainless Steel  
150 lb., 300 lb., & 600 lb.



## Style TC

Temporary Cone Strainer  
Carbon Steel & Stainless Steel  
150 lb., 300 lb., & 600 lb.

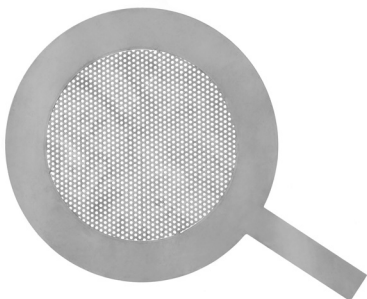

## Fabricated Temporary Cone, Basket, & Plate Strainers

### APPLICATIONS

Steam, water, oil or gas where protection from foreign matter in a pipeline is required. These strainers are installed between flanges for inexpensive protection of mechanical equipment.

### CONSTRUCTION

The Keckley Style TC, TB & TP strainers are available in carbon steel, stainless steel, and other alloys.

Screens are available perforated, mesh, or mesh lined to meet specific media requirements.

### STANDARD SCREENS

The Keckley Style TC, TB & TP strainers are normally supplied with 1/8" diameter holes on 3/16" centers.

### WHEN ORDERING SPECIFY

- Pipe Size
- Style
- Pressure Rating
- Perforation or Mesh Size
  - If mesh lined, specify direction of flow.
- Material of Construction



Unless otherwise specified, standard 1/8" perforations, 150-300 lb. flanges and 150% open area will be supplied.

# Style TC, TB & TP

**Fabricated Temporary Cone, Basket & Plate Strainer**  
**150 lb., 300 lb. & 600 lb.**  
**Cast Steel & Stainless Steel**

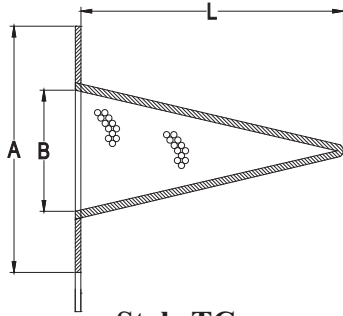

**Style TC**  
**Cone Strainer**

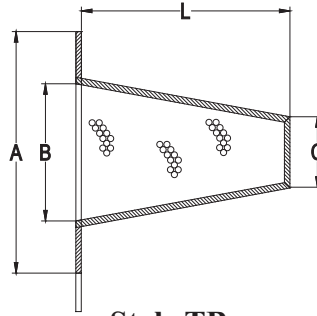

**Style TB**  
**Basket Strainer**

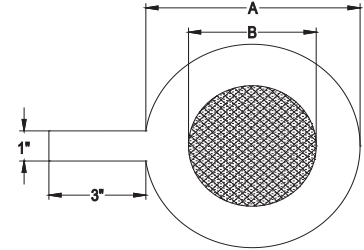

**Style TP**  
**Plate Strainer**

SIZE		DIMENSIONS									
		A				B				C	
		150 - 300 (std)		600 lb.		All Flange Ratings		All Flange Ratings			
in	mm	in	mm	in	mm	in	mm	in	mm		
1-1/2	40	3-1/4	83	3-5/8	92	1-1/4	32	3/4	19		
2	50	4	102	4-1/4	108	1-3/4	44	1	25		
2-1/2	65	4-3/4	121	5	127	2-1/4	57	1-1/4	32		
3	80	5-1/4	133	5-3/4	146	2-3/4	70	1-1/2	38		
4	100	6-3/4	171	7-1/2	191	3-3/4	95	2	51		
5	125	7-5/8	194	9-3/8	238	4-5/8	117	2-1/2	64		
6	150	8-5/8	219	10-3/8	264	5-3/8	137	3	76		
8	200	10-7/8	276	12-1/2	318	7-3/8	184	4	102		
10	250	13-1/4	337	15-5/8	397	9-3/8	238	5	127		
12	300	16	406	17-7/8	454	11	279	6	152		
14	350	17-3/8	441	19	483	12-1/4	311	7	178		
16	400	20-1/8	511	21-7/8	556	14	356	8	203		
18	450	21-1/4	540	23-3/4	603	15-3/4	400	9	229		
20	500	23-1/2	597	26-5/8	676	17-1/2	445	10	254		
24	600	27-7/8	708	30-7/8	784	21-1/4	540	12	305		

SIZE		L 1/8" PERFORATED ON 3/16" CENTERS (% OPEN AREA COMPARED TO CROSS SECTION OF SCHEDULE 40 PIPE)											
		Cones						Baskets					
		100%		150% (std)		200%		100%		150% (std)		200%	
in	mm	in	mm	in	mm	in	mm	in	mm	in	mm	in	mm
1-1/2	40	3-3/16	81	4	102	5	127	2-3/4	70	2-7/8	73	3	76
2	50	3-1/2	89	6	152	8	203	3	76	3-1/2	89	4	102
2-1/2	65	4-1/16	103	6-1/4	159	8	203	3-3/16	81	3-7/8	98	4-1/2	114
3	80	4-1/4	108	6-3/4	171	9	229	3-1/2	89	3-7/8	98	5-1/2	140
4	100	5	127	10	254	12	305	4	102	5	127	7	178
5	125	6	152	12	305	14	356	5	127	6-3/8	162	9	229
6	150	7	178	13	330	18	457	6	152	7-3/4	197	11	279
8	200	8-3/16	208	17	432	23	584	6-1/8	156	9-3/4	248	14	356
10	250	12	305	22	559	28	711	7-1/2	191	12-3/8	314	18	457
12	300	13	330	26	660	34	864	9	229	14-3/4	375	20	508
14	350	15	381	27	686	36	914	10	254	15-7/8	403	21	533
16	400	17	432	30	762	40	1016	10	254	18-3/8	467	23	584
18	450	19	483	35	889	46	1168	12	305	20-7/8	530	27	686
20	500	21	533	39	991	51	1295	14	356	23-1/2	597	31	787
24	600	25	635	45	1143	61	1549	16	406	28-3/8	721	37	940

Consult factory for sizes not shown.

†This table reflects only the nearest metric equivalents.

## Style FLB

Fabricated Line Blinds  
Carbon Steel & Stainless Steel  
150 lb. to 2500 lb.  
Flanged or Butt Weld

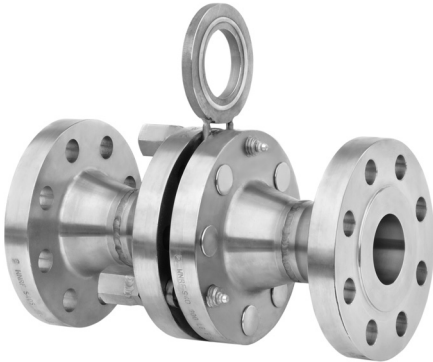

## Quick Acting Line Blinds

### APPLICATIONS

Keckley's Quick Acting Line Blinds are designed for applications where positive, visual indication of line closure/opening are required.

### FEATURES

The position of the spectacle plate indicates whether the line is open or closed, reducing or eliminating the possibility of costly or dangerous situations. Keckley Quick Acting Line Blinds utilize O-ring seals to achieve the most effective shutoff. Our standard O-ring is located in the dovetail groove in both faces of the spectacle plate.

Two stainless steel guide pins are located in the face of the body flange to ensure accurate alignment of the spectacle plate with the bore.

With the Keckley Quick Acting Line Blind, one operator can change a 6" Line Blind in five minutes without the need for special tools as compared to a typical 6" spectacle blind, which takes two maintenance men approximately 1-12 hours to change over.

### CONSTRUCTION

The standard model has a carbon steel body and zinc plated carbon steel trim. Stainless steel and other alloys are also available to meet your specific requirements. All units are available flanged or butt weld.

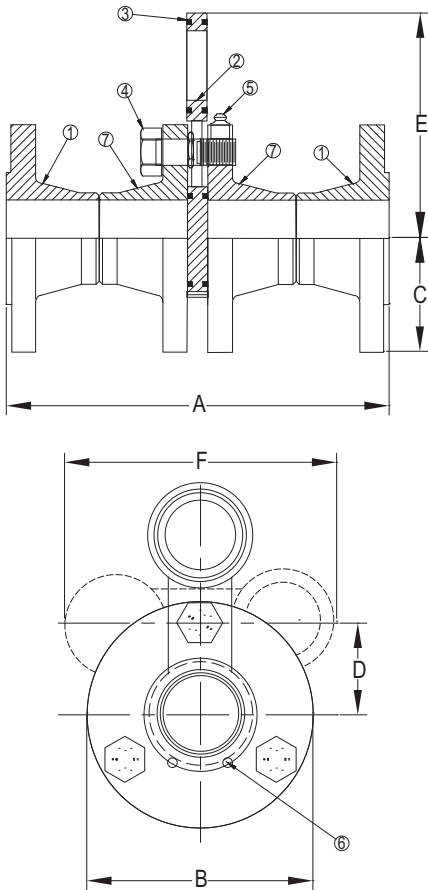

# Style FLB

**Fabricated Line Blinds**  
**150 lb. to 2500 lb. Flanged & Butt Weld**  
**Carbon Steel & Stainless Steel**

PARTS LIST		
ITEM	DESCRIPTION	MATERIAL
1	RFWN Flange	Carbon Steel (ASTM A 105) B16.5
2	Spectacle Plate	Carbon Steel (ASTM A 36)
3*	O-ring	Buna-N
4	Pivot Bolt / Spreader Bolt	Carbon Steel (SAE J 429, Grade 8)
5	Grease Fitting (Qty. 3)	
6	Spring Pins	Stainless Steel (304)

\*Buna-N o-ring good for temperatures up to 250°F. For higher temperatures, consult factory.

Pipe Size		DIMENSION - 150# CLASS											
		A		B		C		D		E		F	
in	mm	in	mm	in	mm	in	mm	in	mm	in	mm	in	mm
1	25	9	229	4-1/4	108	2-1/8	54	1-9/16	40	4-3/8	111	5-5/8	143
1-1/2	40	10	254	5	127	2-1/2	64	1-15/16	49	5-1/2	140	7-1/8	181
2	50	10-3/8	264	6	152	3	76	2-3/8	60	6-3/4	171	8-3/4	222
2-1/2	65	11-3/8	289	7	178	3-1/2	89	2-3/4	70	7-7/8	200	10-1/4	260
3	80	11-3/8	289	7-1/2	191	3-3/4	95	3	76	8-5/8	219	11-1/4	286
4	100	12-1/2	318	9	229	4-1/2	115	3-3/4	95	10-7/8	276	14-1/4	362
5	125	14-5/8	371	10	254	5	127	4-1/4	108	10-7/8	276	14-1/4	362
6	150	14-5/8	371	11	274	5-1/2	140	4-3/4	121	13-13/16	351	18-1/8	460
8	200	16-5/8	422	13-1/2	343	6-3/4	171	5-7/8	149	17-3/16	437	22-5/8	575
10	250	16-3/4	425	16	406	8	203	7-1/8	181	20-7/8	530	27-1/2	699
12	300	18-7/8	479	19	483	9-1/2	241	8-1/2	216	25	635	33	838
14	350	20-7/8	530	21	533	10-1/2	267	9-3/4	248	27-1/2	699	36-1/4	921
16	400	21	533	23-1/2	597	11-3/4	299	10-5/8	270	31-1/4	794	41-1/4	1048
18	450	23-1/8	587	25	635	12-1/2	318	11-3/8	289	33-7/16	849	44-1/8	1121
20	500	24	610	27-1/2	699	13-3/4	350	12-1/2	318	36-13/16	935	48-5/8	1235
24	600	25-3/8	645	32	813	16	407	14-3/4	375	43-1/2	1105	57-1/2	1461

Certified dimensional drawings are available upon request.

\*This table reflects only the nearest metric equivalents.

Size		WEIGHTS															
		1"	1-1/2"	2"	2-1/2"	3"	4"	5"	6"	8"	10"	12"	14"	16"	18"	20"	24"
Butt Weld	lbs	7	9	14	23	26	38	52	62	104	143	238	302	407	469	582	851
	kgs	3.2	4.1	6.4	10	12	17	24	28	47	65	108	137	185	213	264	386
Flanged	lbs	13	17	26	43	49	71	94	114	188	251	414	530	687	799	976	1387
	kgs	5.9	7.7	12	20	22	32	43	52	85	114	188	240	312	362	443	629

# Style FBO

Fabricated Basket - Offset

Bolted Cover

Carbon Steel & Stainless Steel

150 lb. Flanged & Butt Weld

300 lb. Flanged & Butt Weld

600 lb. Flanged & Butt Weld

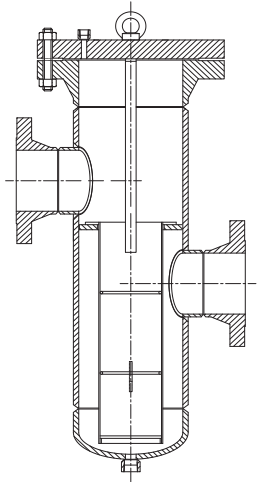

## Flanged Offset Basket Strainer

### APPLICATIONS

Water, oil or gas where protection from foreign matter in a pipeline is required.

### CONSTRUCTION

These strainers can be fabricated to any specifications. The offset flanges allow easy connection for a wide variety of pump installations. These strainers are available in carbon steel, 304 stainless steel, and 316 stainless steel.

### FEATURES

These strainers have been designed to answer the specific need for an extremely large capacity strainer requiring minimum down time for cleaning and are ideal for very fine straining. The basket and seat are designed to eliminate sediment by-pass for particle sizes as small as five micron. The low outlet design lends itself to pump installations where the suction is located close to the floor.

### BASKETS

Standard baskets are perforated 304 stainless steel. All baskets are spot welded for maximum strength. Different size perforations and meshes are available in stainless steel, monel, and brass to meet specific media requirements. If media is not indicated, 1/8" perforated 304 stainless steel baskets will be supplied.

## Optional Features

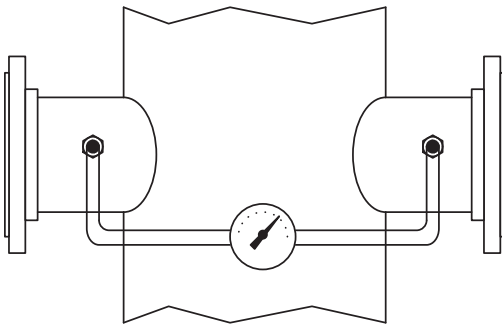

Differential Pressure Gauge

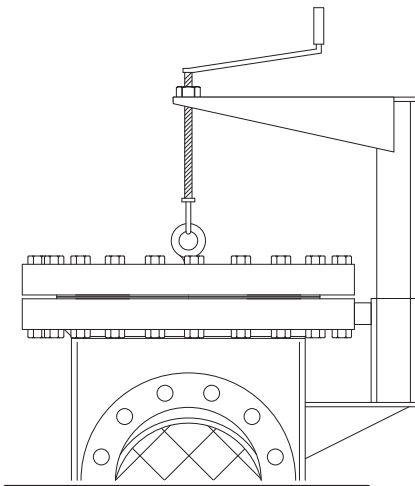

Integral Davit Swing Arm

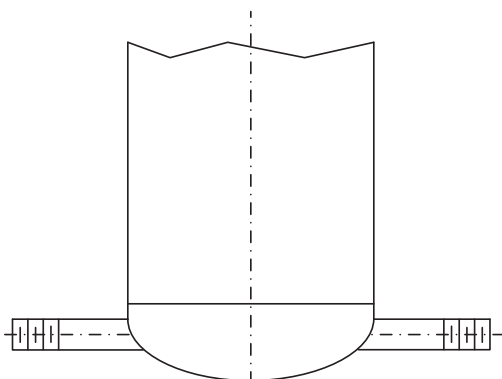

Special Drains

### SPECIAL OPTIONS ON FABRICATED STRAINERS

- Differential Pressure Gauges
- Custom Nozzle Positions
- Custom Blowdown Connections
- Custom Venting
- Custom Basket Configurations
- Special Coatings and Galvanizing
- Custom Floor Stands and Mounting Hardware
- Oversized Bodies

### DATA REQUIRED WHEN ORDERING

- Inlet and Outlet Size
- End Connections (Flange or Butt Weld)
- If Offset, Specify Dimensions
- Body Rating
- Design Pressure and Temperature
- Capacity Requirements
- Screen Material and Perforation/Mesh Size



# PRESSURE DROP CHART

## Fabricated Y-Type Strainers

This pressure drop chart is based on the flow of clean water through the Keckley fabricated Y-Type strainers with a 1/8" perforated screen.

### TO USE CHARTS:

Find your desired rate of flow (GPM) on the left hand side of the chart. Follow its corresponding horizontal line to the point where it intersects the diagonal line indicating the strainer pipe size. From this point of intersection, follow the vertical line down to the bottom of the chart to determine the approximate pressure drop.

### CORRECTION FACTORS:

For finer mesh baskets that are backed with a perforated sheet, multiply the pressure drops shown at right by the following:

- 40 mesh        x 1.2
- 60 mesh        x 1.4
- 80 mesh        x 1.6
- 100 mesh       x 1.7

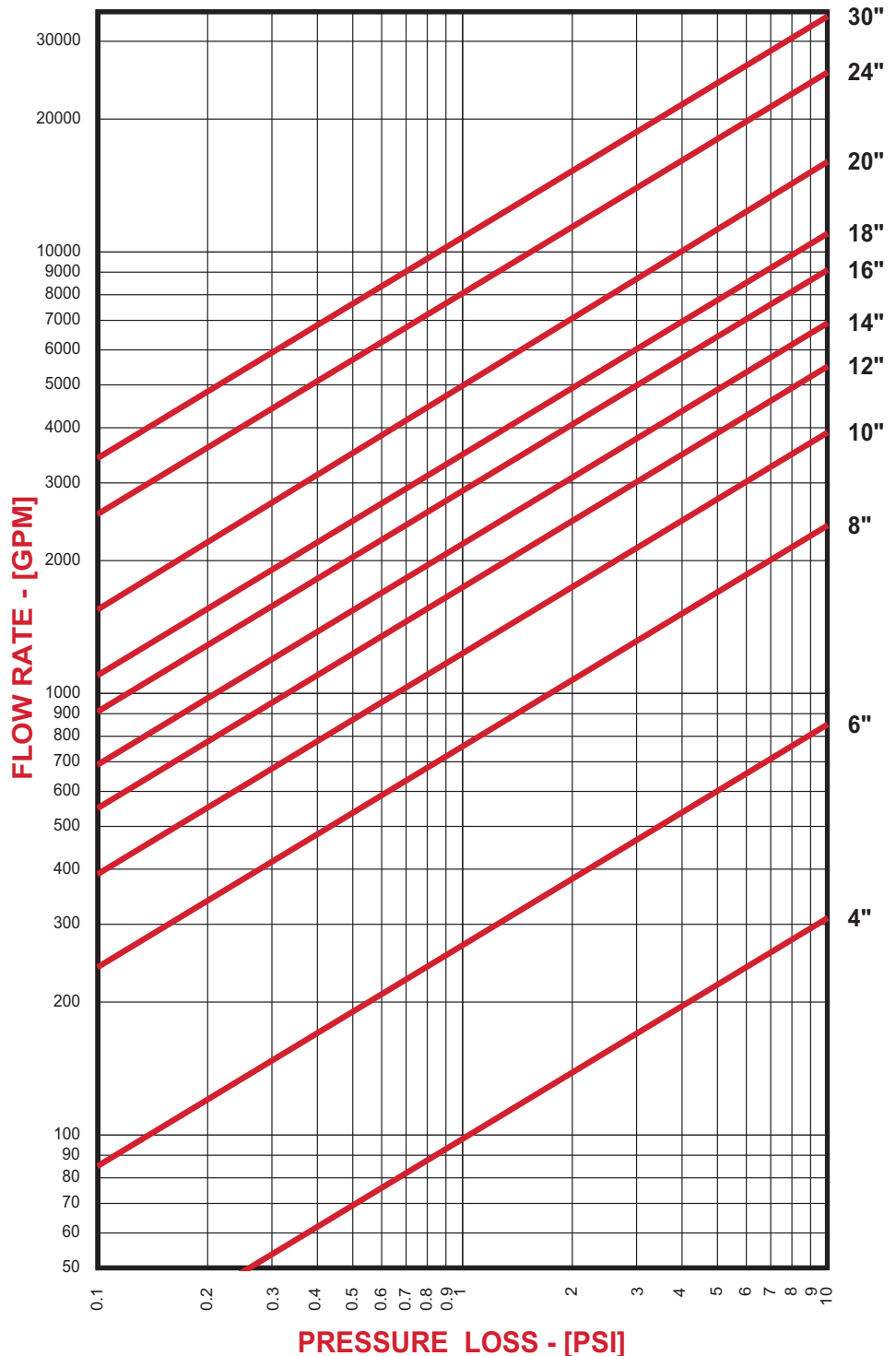



## PRESSURE DROP CHART

### Fabricated Basket Strainers

This pressure drop chart is based on the flow of clean water through the Keckley fabricated basket strainers with a 1/8" perforated basket.

#### TO USE CHARTS:

Find your desired rate of flow (GPM) on the left hand side of the chart. Follow its corresponding horizontal line to the point where it intersects the diagonal line indicating the strainer pipe size. From this point of intersection, follow the vertical line down to the bottom of the chart to determine the approximate pressure drop.

#### CORRECTION FACTORS:

For finer mesh baskets that are backed with a perforated sheet, multiply the pressure drops shown at right by the following:

40 mesh	x 1.2
60 mesh	x 1.4
80 mesh	x 1.6
100 mesh	x 1.7

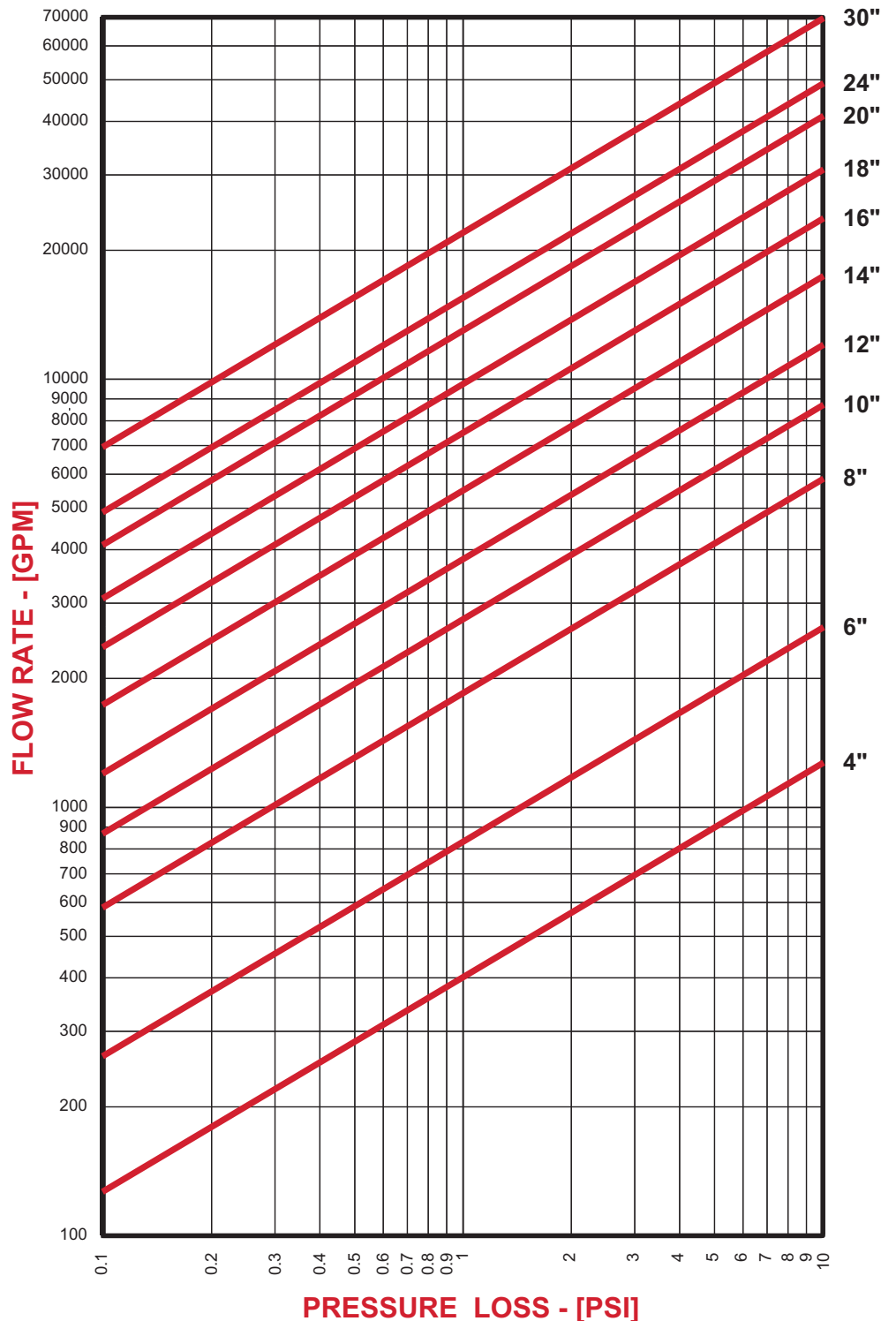



# PRESSURE DROP CHART

## Fabricated T-Type Strainers

This pressure drop chart is based on the flow of clean water through the Keckley Fabricated T-Type strainers with 1/8" perforations (approximately 6 mesh).

### TO USE CHARTS:

Find your desired rate of flow (GPM) on the left hand side of the chart. Follow its corresponding horizontal line to the point where it intersects the diagonal line indicating the strainer pipe size. From this point of intersection, follow the vertical line down to the bottom of the chart to determine the approximate pressure drop.

### CORRECTION FACTORS:

For finer mesh baskets that are backed with a perforated sheet, multiply the pressure drops shown at right by the following:

- 40 mesh      x 1.2
- 60 mesh      x 1.4
- 80 mesh      x 1.6
- 100 mesh     x 1.7

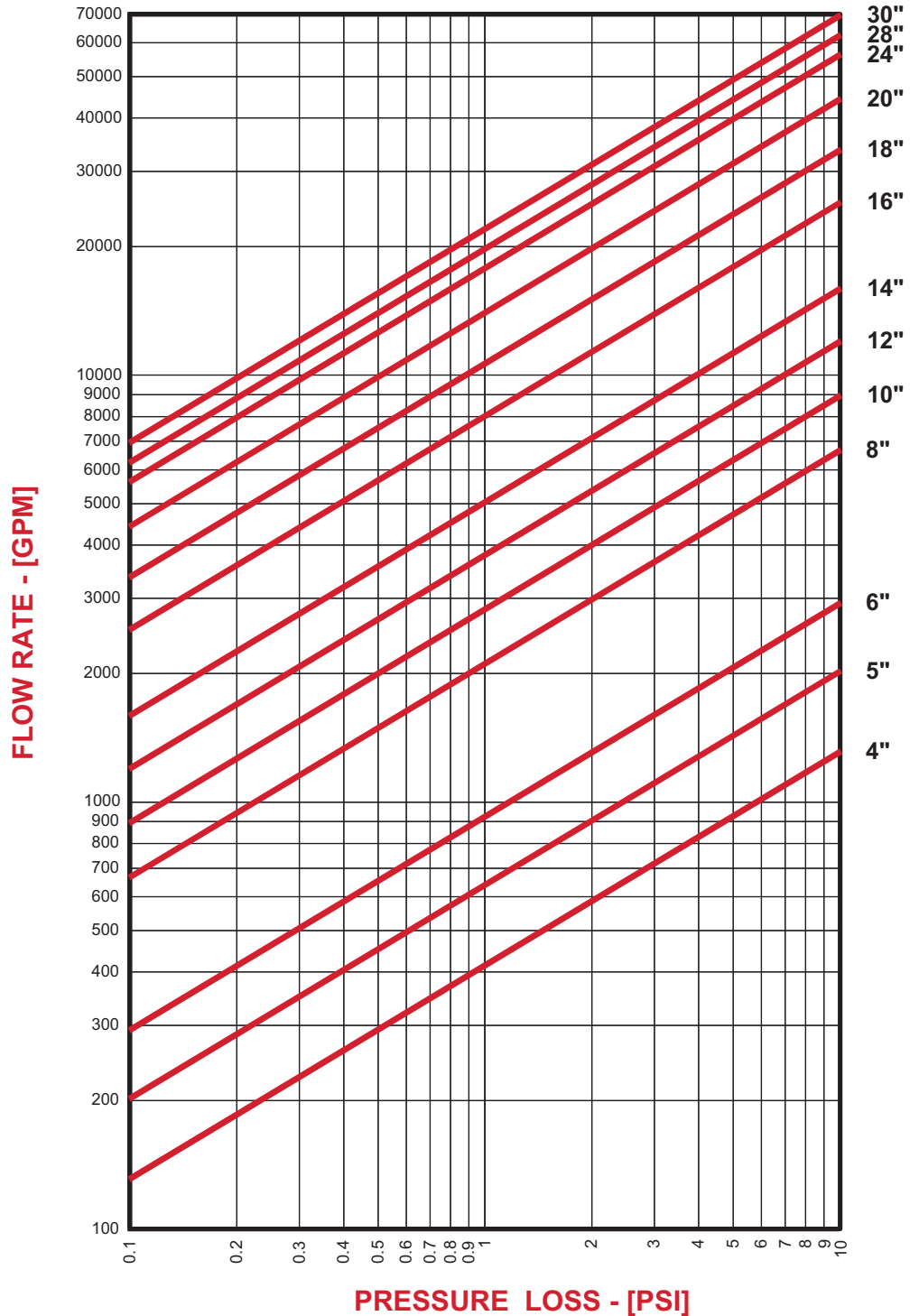

## PRESSURE DROP CHART

### Fabricated Temporary Cone/Basket Strainers

This pressure drop chart is based on the flow of clean water through the Keckley strainer styles listed above with screen perforations ranging from 3/64" through 1/8".

#### TO USE CHARTS:

Find your desired rate of flow (GPM) on the left hand side of the chart. Follow its corresponding horizontal line to the point where it intersects the diagonal line indicating the strainer pipe size. From this point of intersection, follow the vertical line down to the bottom of the chart to determine the approximate pressure drop.

#### CORRECTION FACTORS:

For finer mesh baskets that are backed with a perforated sheet, multiply the pressure drops shown at right by the following:

40 mesh	x 1.2
60 mesh	x 1.4
80 mesh	x 1.6
100 mesh	x 1.7

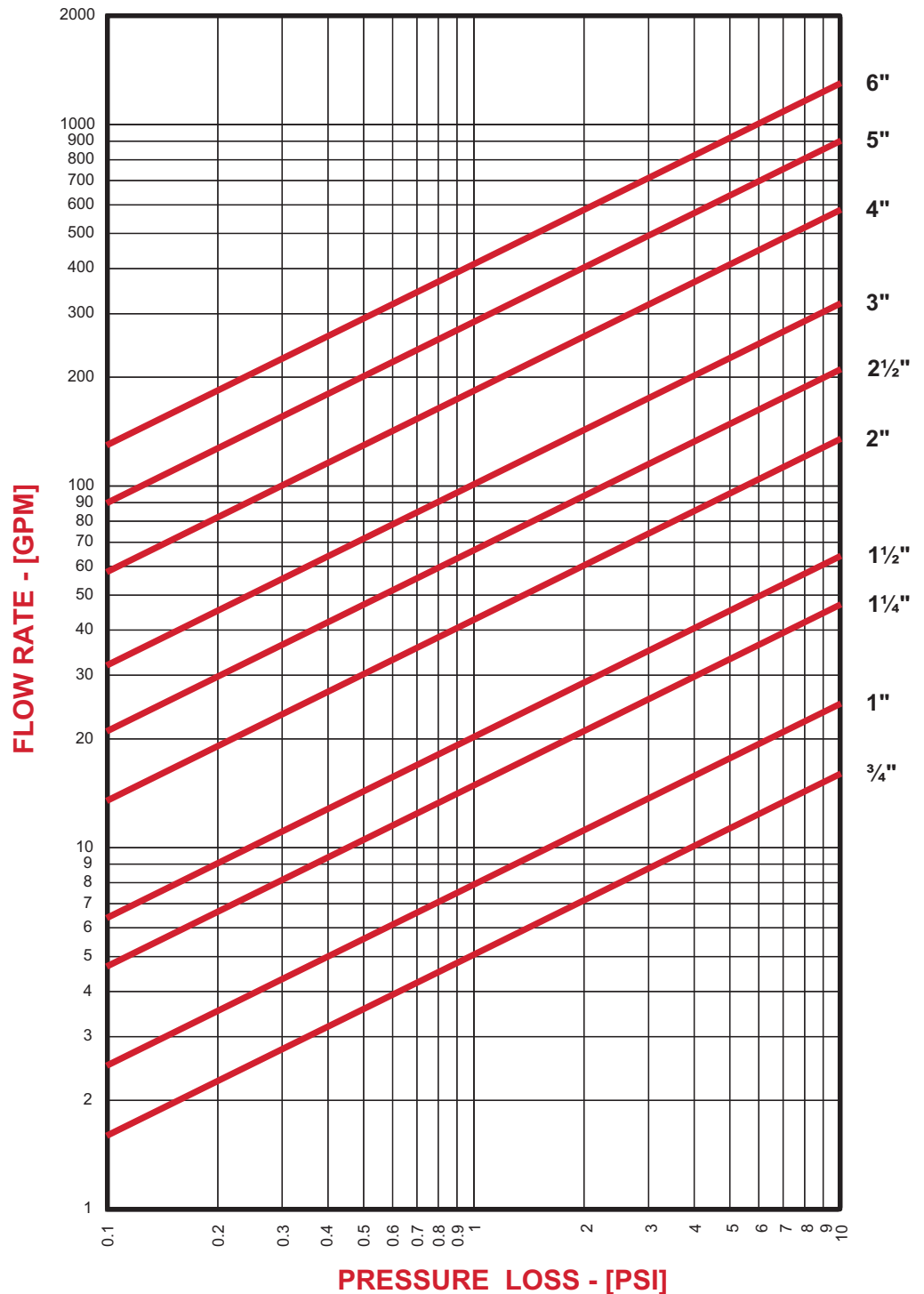



# PRESSURE DROP CHART

## Fabricated Temporary Cone/Basket Strainers

This pressure drop chart is based on the flow of clean water through the Keckley strainer styles listed above with screen perforations ranging from 3/64" through 1/8".

**TO USE CHARTS:**

Find your desired rate of flow (GPM) on the left hand side of the chart. Follow its corresponding horizontal line to the point where it intersects the diagonal line indicating the strainer pipe size. From this point of intersection, follow the vertical line down to the bottom of the chart to determine the approximate pressure drop.

**CORRECTION FACTORS:**

For finer mesh baskets that are backed with a perforated sheet, multiply the pressure drops shown at right by the following:

- 40 mesh      x 1.2
- 60 mesh      x 1.4
- 80 mesh      x 1.6
- 100 mesh     x 1.7

